

|      |      | REVISIONS   |      |          |  |
|------|------|-------------|------|----------|--|
| ZONE | REV. | DESCRIPTION | DATE | APPROVED |  |
|      |      |             |      |          |  |

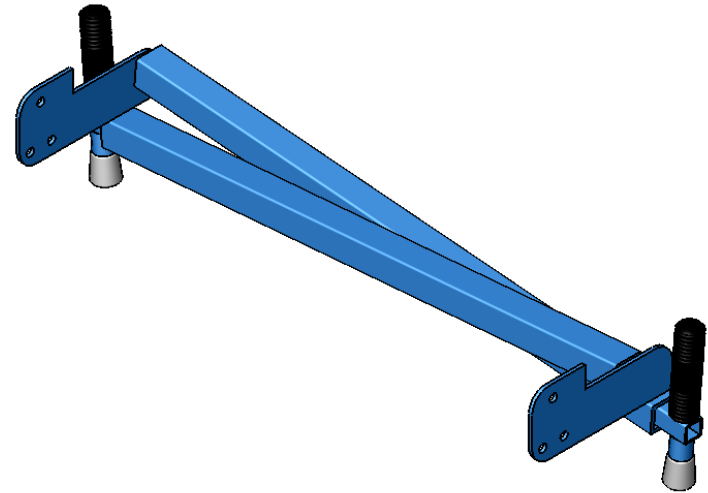
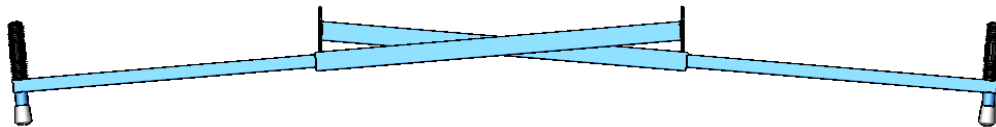
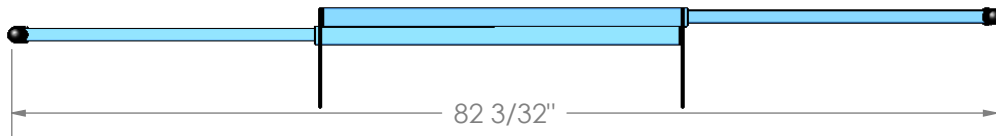
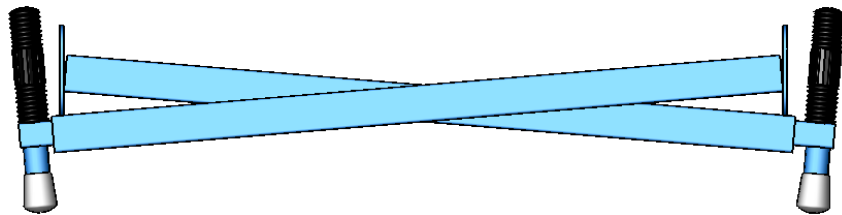
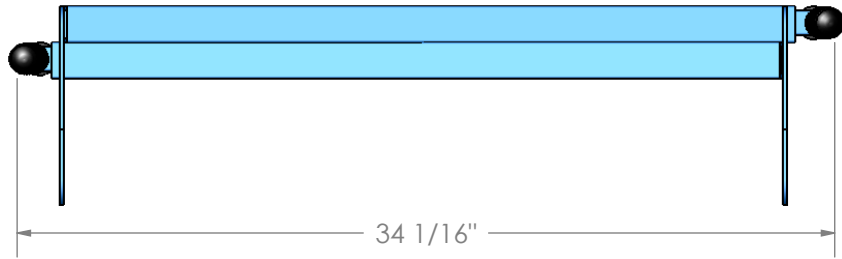

**PROPRIETARY AND CONFIDENTIAL**  
 THE INFORMATION CONTAINED IN THIS DRAWING IS THE SOLE PROPERTY OF Unitran Manufacturers Ltd. ANY REPRODUCTION IN PART OR AS A WHOLE WITHOUT THE WRITTEN PERMISSION OF Unitran Manufacturers Ltd. IS PROHIBITED.

DIMENSIONS ARE IN INCHES  
 TOLERANCES:  
 FRACTIONAL  $\pm 1/32"$   
 ANGULAR: MACH  $\pm .5$  BEND  $\pm .5$   
 TWO PLACE DECIMAL  $\pm .010$   
 THREE PLACE DECIMAL  $\pm .005$   
 UNLESS OTHERWISE STATED

MATERIAL  
  
 DO NOT SCALE DRAWING

|           | NAME    | DATE  |
|-----------|---------|-------|
| DRAWN     | Dean S. | 2/8/8 |
| CHECKED   |         |       |
| ENG APPR. |         |       |
| MFG APPR. |         |       |

COMMENTS:

Unitran Manufacturers

890/LS2

|          |         |              |  |
|----------|---------|--------------|--|
| DWG. NO. | U-0597  | REV.         |  |
| SCALE:   | WEIGHT: | SHEET 1 OF 1 |  |